

DALLMER

FRESCOLORI®

2-STAGE FILLER

ONLY ONE DRAINAGE LEVEL

100 % SAFE

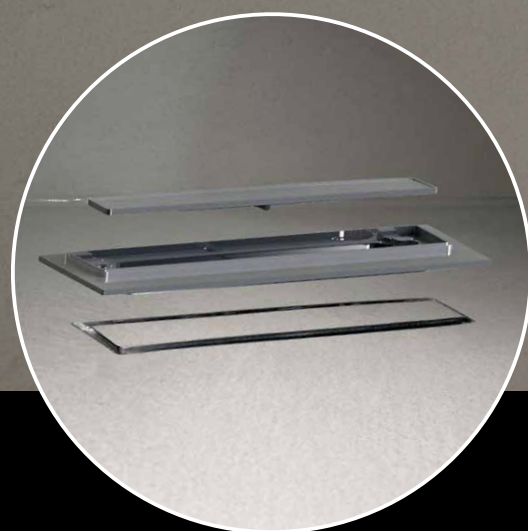

PURAMENTE® Drain

The system for seamless showers –
DALLMER CeraFrame Liquid and FRESCOLORI PURAMENTE®

PURAMENTE® Drain – the system for seamless shower

DALLMER is expanding its product range by a new type of water removal system, which has been developed especially for thin-layer filler systems.

A shower channel has been created together with the development partner FRESCOLORI®, which caters to all the special features of removing water from seamless thin-layer coatings – the CeraFrame Liquid. Eliminating the second drainage level enables seamless installation directly into the cement screed. Thus, the interfaces between the trades can be reduced to a minimum. The 2-stage filler supports

the precise application of both the sealant layer as well as the floor covering. There is no tile thickness to be bridged and the thickness of the PURAMENTE® floor covering including the seal totals 4.5 mm.

The particularly flat and spreadable insert is the optical highlight of the CeraFrame Liquid and fits seamlessly into the puristic and elegant look of the PURAMENTE® system.

Special features of the PURAMENTE® Drain system

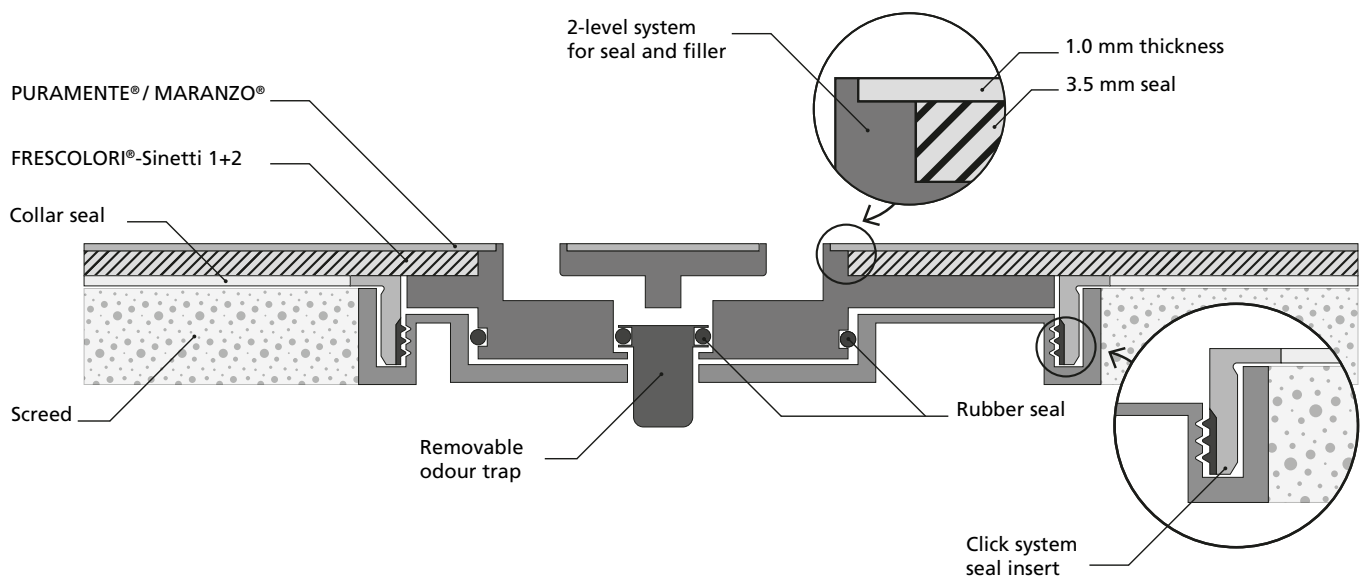

Advantages of the PURAMENTE® Drain system

- 2-stage filler aid
- Seamless installation directly into the cement screed
- Only one drainage level
- Buildup thickness of 4.5 mm including seal

Drain with system

The CeraFrame Liquid in the PURAMENTE® Drain System is adapted to the DallFlex drain casing standard. This has an odour trap that can be removed upwards in accordance with DIN 1986-100. The factory supplied collar seal according to DIN 18534 is included in the scope of delivery. Fire and noise protection can be integrated as an option. A ball joint connection with three connection options is installed

to ensure maximum independence. The high-quality metal cover complements the PURAMENTE® Drain system. A tried and tested system with a low installation height from 69.5 mm onwards and an installation height of upper edge finished floor from 79.5 mm and up, a removable and easy-to-clean cover and a removable odour trap.

PURAMENTE® – certified according to ETAG 022 ANNEX A+F

Thanks to the high material quality and the special composition of the PURAMENTE® surfaces, there are no heat and moisture concerns. PURAMENTE® stands out because of its special finish, which is water resistant and, above all, easy to clean.

In addition, more than 15 structures, endless colours and countless design variants, leave your individuality free of any boundaries. FRESCOLORI® has more than 20 years of experience in wet zones and is strictly based on the guidelines of the European Technical Approval Guidelines (ETAG).

This is confirmed by the severe impermeability and quality tests according to the ETAG 022 Annexe A+F standard, which PURAMENTE® has passed with flying colours.

Awarded with: ICONIC Award 2020 innovative interior in the "best of best" category, German Innovation Award 2020 in the Heating & Bath category, winner of the "Bath comfort for generations" 2021 award of ZVSHK (German Central Association Plumbing, Heating, and Air Conditioning).

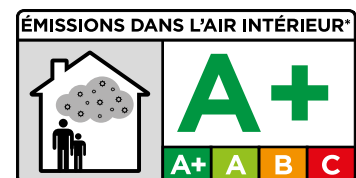
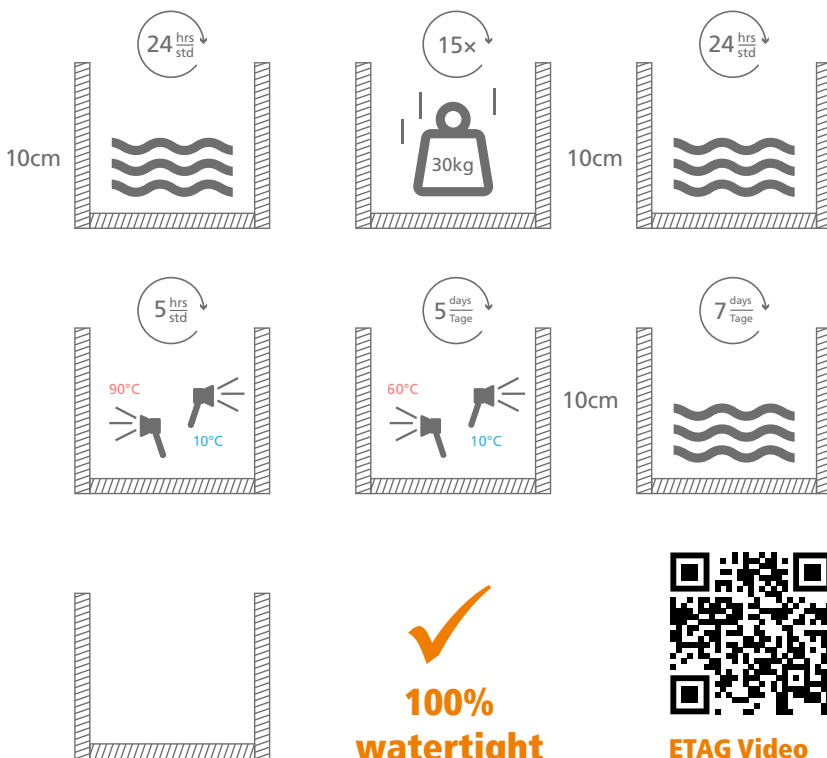

Cleaning and Care

